

# PRORIL

60Hz

X-SMART Series, all components in contact with liquid of the stainless steel dewatering pumps are made of 304 stainless steel. These pumps are designed for handling clean water or screened wastewater. With the use of the food-graded lubricant, they are also applicable to the aquaculture industry.

## Stainless Steel Pump

# X-SMART 400/750

Dewatering Pump



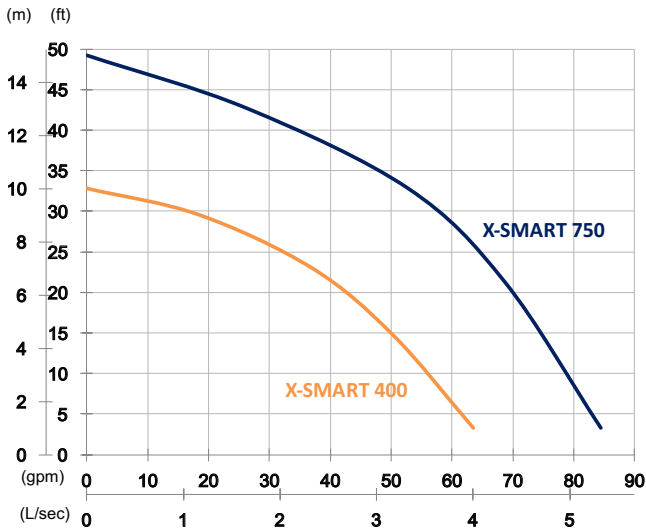

	X-SMART 400	X-SMART 750
<b>OUTPUT</b>	0.5 HP (0.4 kW)	1 HP (0.75 kW)
<b>OUTLET</b>	2" (50 mm)	2" (50 mm)
<b>SOLID PASSAGE</b>	0.2" (5.5 mm)	0.3" (7 mm)
<b>Weight</b>	29 lbs/13 kg	31 lbs/14 kg
<b>HEAD</b>	Rated: 23 ft, 7 m Max: 33 ft, 10 m	Rated: 33 ft, 10 m Max: 49 ft, 15 m
<b>FLOW</b>	Rated: 37 gpm, 2.3 L/s Max: 63 gpm, 4 L/s	Rated: 53 gpm, 3.3 L/s Max: 85 gpm, 5.3 L/s

<b>Pump Type</b>	Electric Submersible Pumps	
<b>Motor</b>	<b>Phase</b>	1-Phase, 3-Phase
	<b>Type</b>	Induction Motor
	<b>Poles</b>	2 Pole (3450 rpm)
	<b>Insulation</b>	Class F
	<b>Protector</b>	Circle Thermal Protector
	<b>Starter</b>	1-Phase Capacitor-Run, 3-Phase D.O.L.
<b>Lubricant</b>	Food Grade (ISO VG32)	
<b>Specs.</b>	<b>Impeller Type</b>	Opened
	<b>Shaft Seal</b>	Double Mechanical Seal
		Silicon Carbide VS Ceramic/Carbon
	<b>Bearings</b>	C3 Shielded ball bearings
	<b>Cable</b>	CSA-Certified PVC Jacketed Cables
33 ft (10 m) or longer upon request		
<b>Materials</b>	<b>Pump Casing</b>	Stainless Steel
	<b>Impeller</b>	Stainless Steel
	<b>Motor Frame</b>	Stainless Steel
	<b>Motor Shaft</b>	Stainless Steel
	<b>Strainer</b>	Stainless Steel
<b>Max. Liquid Temperature</b>	40°C (104°F)	
<b>Max. Submersion Depth</b>	20 m (66 ft)	
<b>pH Range</b>	pH 5 - pH 8	

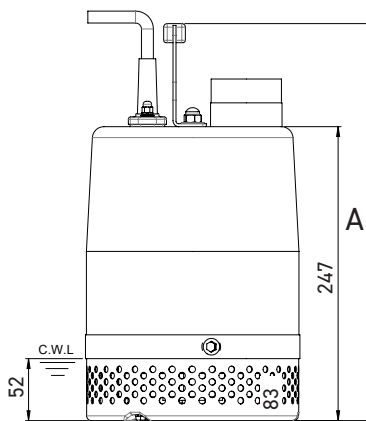
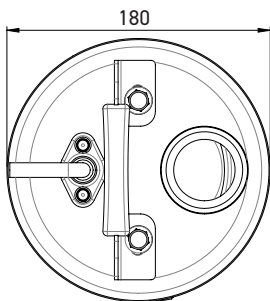

X-SMART 400	333
X-SMART 750	361

unit : mm  
C.W.L : Continuous running water level  
L.W.L : Lowest running water level